

## 7. Diagnostics Chart for ABS Warning Light Circuit and Diagnosis Circuit Failure

**A: ABS WARNING LIGHT DOES NOT COME ON.**

**DIAGNOSIS:**

- ABS warning light circuit is open or shorted.

**TROUBLE SYMPTOM:**

- When ignition switch is turned ON (engine OFF), ABS warning light does not come on.

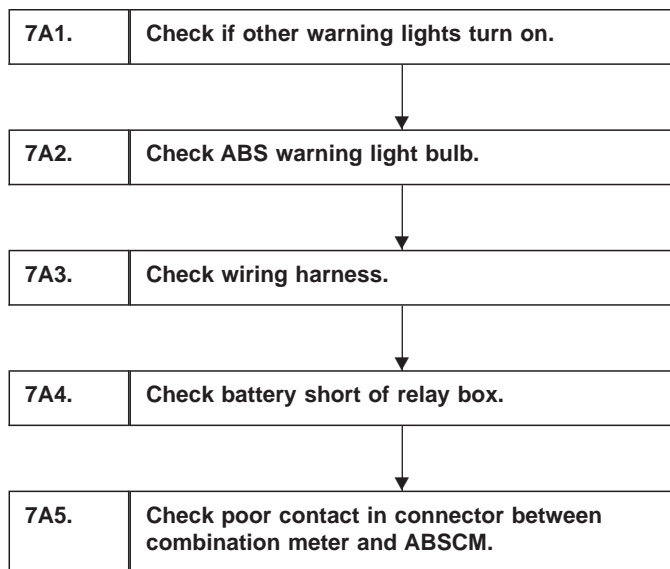

**WIRING DIAGRAM:**

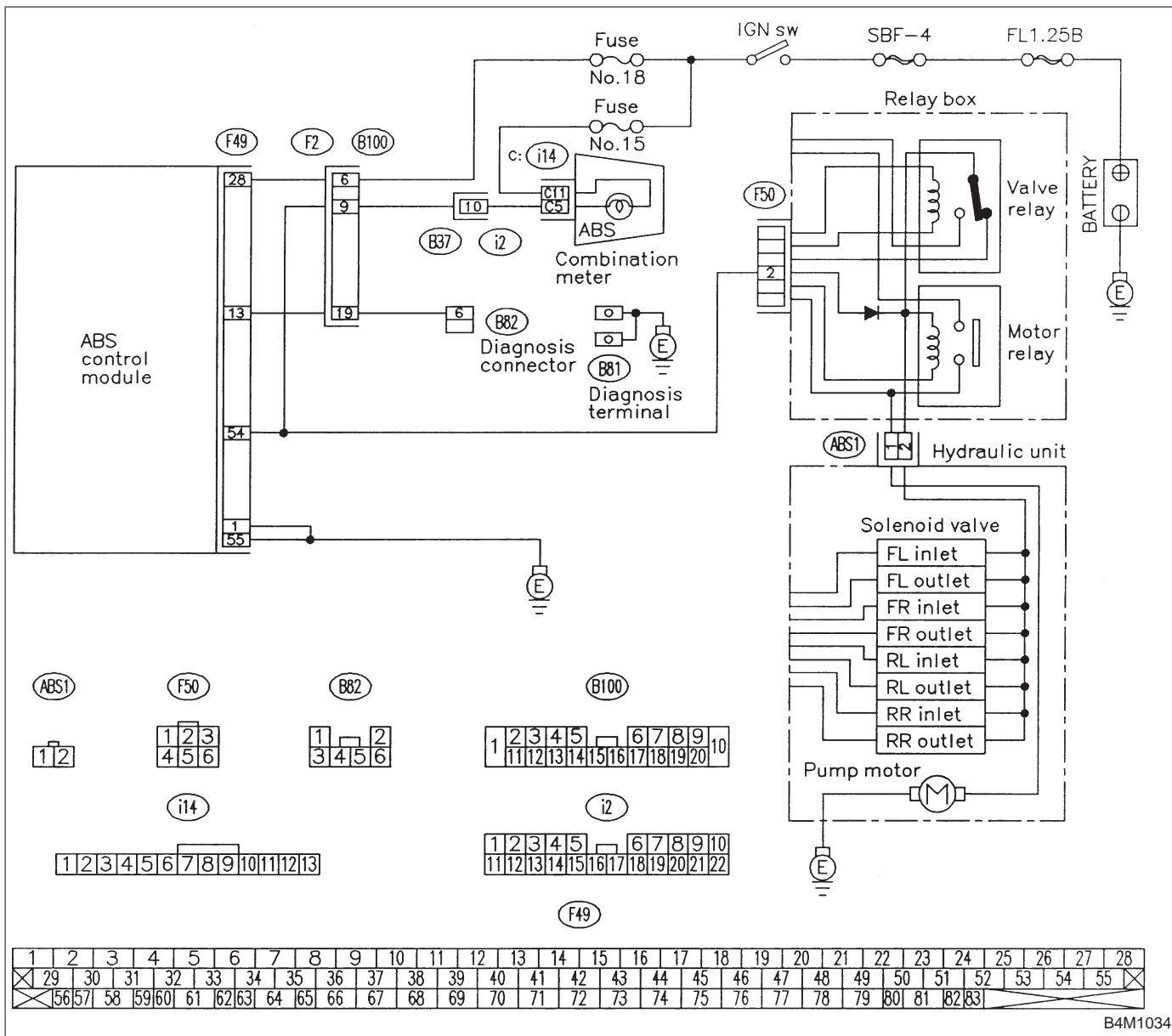

B4M1034

**7A1**      **CHECK IF OTHER WARNING LIGHTS TURN ON.**

Turn ignition switch to ON (engine OFF).

- CHECK** : **Do other warning lights turn on?**
- YES** : Go to step **7A2**.
- NO** : Repair combination meter.

**7A2 CHECK ABS WARNING LIGHT BULB.**

- 1) Turn ignition switch to OFF.
- 2) Remove combination meter.
- 3) Remove ABS warning light bulb from combination meter.

**CHECK** : *Is ABS warning light bulb OK?*

**YES** : Go to step **7A3**.

**NO** : Replace ABS warning light bulb.

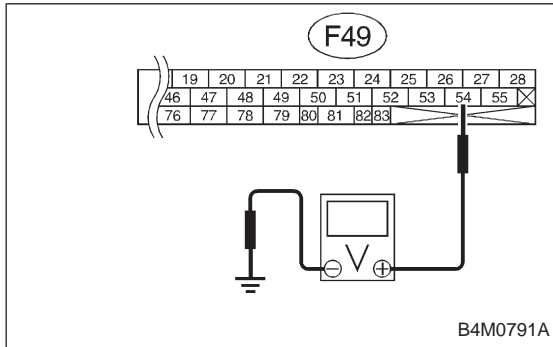
**7A3 CHECK WIRING HARNESS.**

- 1) Disconnect connector from ABSCM.
- 2) Disconnect connector (F50) from relay box.
- 3) Turn ignition switch to ON.
- 4) Measure voltage between connector (F49) and chassis ground.

**CHECK** : **Connector & terminal (F49) No. 54 (+) — Chassis ground (-): Is voltage 12 V?**

**YES** : Go to next step.

**NO** : Repair broken wire in harness or connector.

- 5) Turn ignition switch to OFF.
- 6) Measure voltage between ABSCM connector (F49) and chassis ground.

**CHECK** : **Connector & terminal (F49) No. 54 (+) — Chassis ground (-): Is voltage less than 3 V?**

**YES** : Go to step **7A4**.

**NO** : Repair battery short of harness.

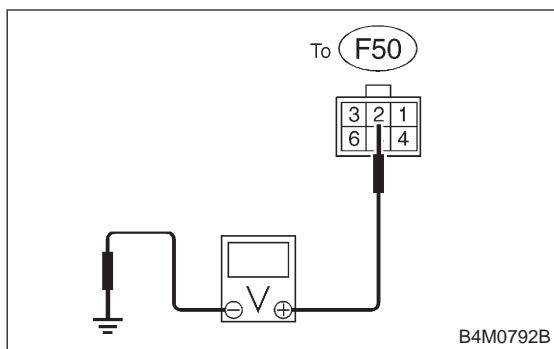
**7A4****CHECK BATTERY SHORT OF RELAY BOX.**

- 1) Disconnect connector from relay box.
- 2) Turn ignition switch to ON.
- 3) Measure voltage between relay box and chassis ground.

**CHECK** : **Connector & terminal**  
**To (F50) No. 2 (+) — Chassis ground (-):**  
**Is voltage 0 V?**

**YES** : Go to next step.

**NO** : Replace relay box.

- 4) Turn ignition switch OFF.
- 5) Measure voltage between relay box and chassis ground.

**CHECK** : **Connector & terminal**  
**To (F50) No. 2 (+) — Chassis ground (-):**  
**Is voltage 0 V?**

**YES** : Go to step **7A5**.

**NO** : Replace relay box.

**7A5****CHECK POOR CONTACT IN CONNECTOR BETWEEN COMBINATION METER AND ABSCM.**

**CHECK** : **Is there poor contact in connectors between combination meter and ABSCM?**

**YES** : Repair connector.

**NO** : Replace ABSCM.

**B: ABS WARNING LIGHT DOES NOT GO OFF.****DIAGNOSIS:**

- ABS warning light circuit is open or shorted.

**TROUBLE SYMPTOM:**

- When starting the engine and while ABS warning light is kept ON.

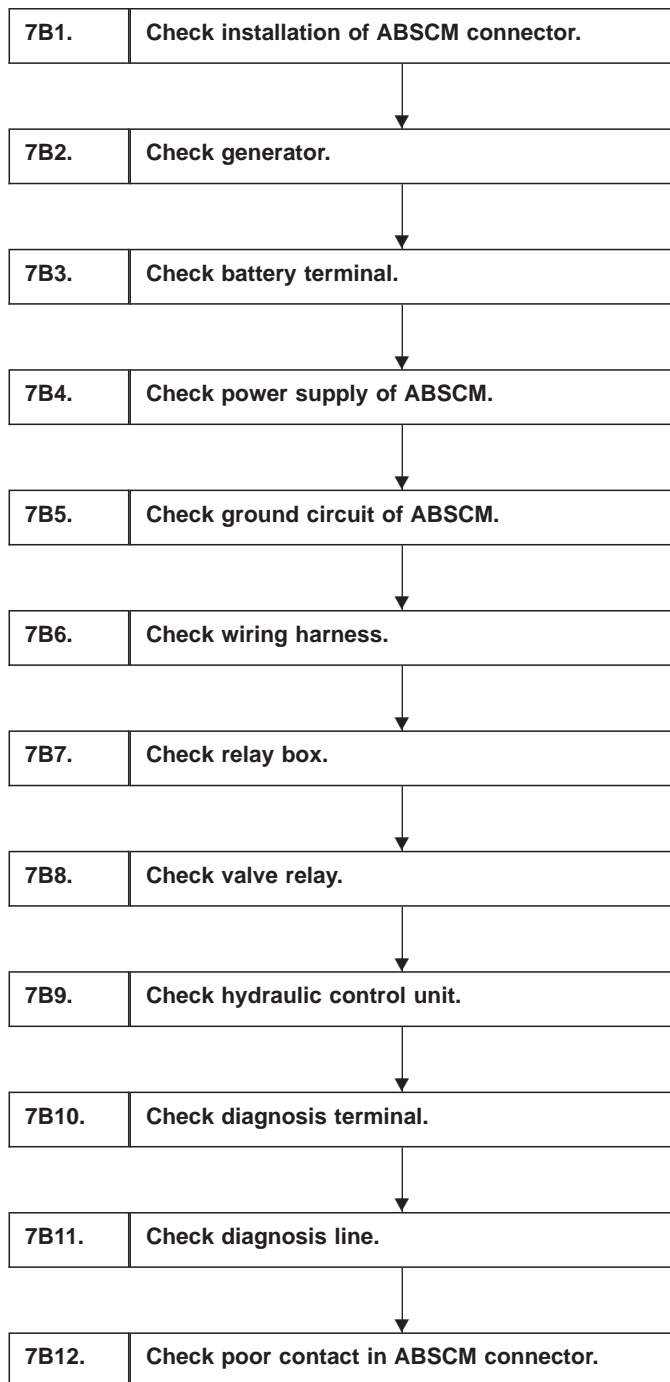

**WIRING DIAGRAM:**

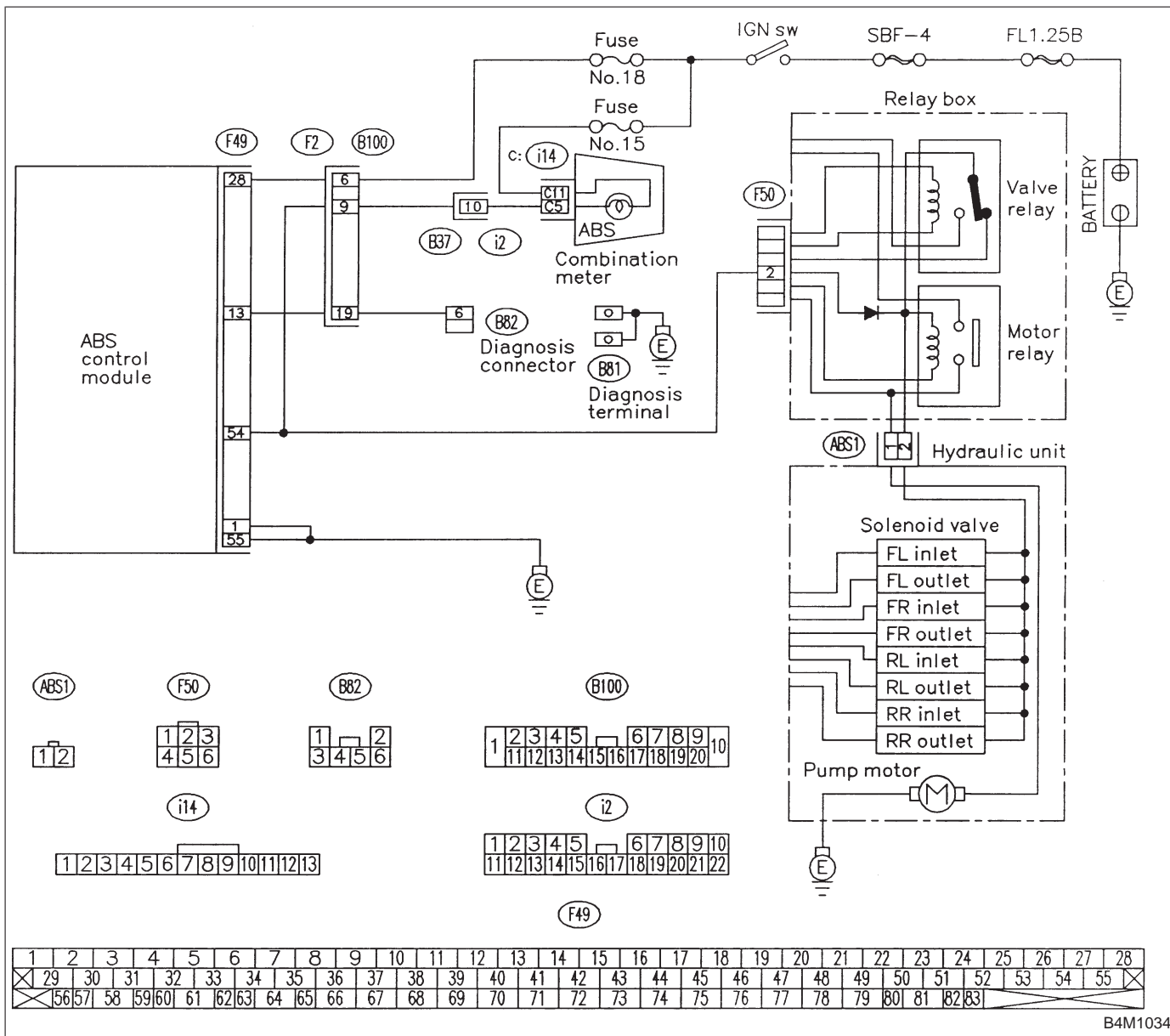

B4M1034

**7B1 CHECK INSTALLATION OF ABSCM CONNECTOR.**

Turn ignition switch to OFF.

**CHECK** : Is ABSCM connector inserted into ABSCM until the clamp locks onto it?

**YES** : Go to step 7B2.

**NO** : Insert ABSCM connector into ABSCM until the clamp locks onto it.

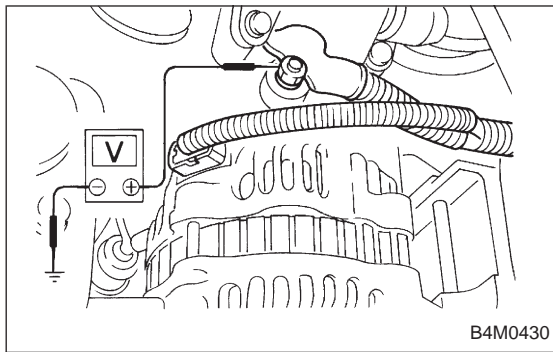

**7B2 CHECK GENERATOR.**

- 1) Start the engine.
- 2) Idle the engine.
- 3) Measure voltage between generator and chassis ground.

**CHECK** : *Terminal Generator B terminal (+) — Chassis ground (-): Is voltage 10 — 15 V?*

**YES** : Go to step 7B3.

**NO** : Repair generator.

**7B3 CHECK BATTERY TERMINAL.**

Turn ignition switch to OFF.

**CHECK** : *Is there poor contact at battery terminal?*

**YES** : Repair battery terminal.

**NO** : Go to step 7B4.

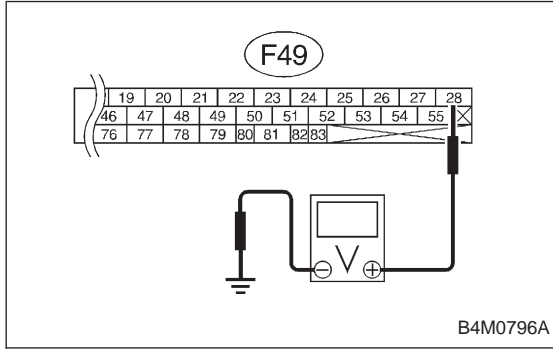

**7B4 CHECK POWER SUPPLY OF ABSCM.**

- 1) Disconnect connector from ABSCM.
- 2) Start engine.
- 3) Idle the engine.
- 4) Measure voltage between ABSCM connector and chassis ground.

**CHECK** : *Connector & terminal (F49) No. 28 (+) — Chassis ground (-): Is voltage 10 — 15 V?*

**YES** : Go to step 7B5.

**NO** : Repair ABSCM power supply circuit.

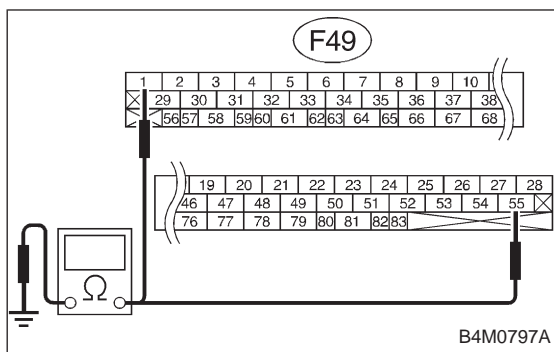

**7B5 CHECK GROUND CIRCUIT OF ABSCm.**

- 1) Turn ignition switch to OFF.
- 2) Measure resistance between ABSCm connector and chassis ground.

**CHECK** : **Connector & terminal**  
**(F49) No. 1 — Chassis ground:**  
**(F49) No. 55 — Chassis ground:**  
**Is resistance less than 0.5 Ω?**

- YES** : Go to step 7B6.  
**NO** : Repair ABSCm ground harness.

**7B6 CHECK WIRING HARNESS.**

- 1) Disconnect connector (F50) from relay box.
- 2) Turn ignition switch to ON.

**CHECK** : **Does the ABS warning light remain off?**  
**YES** : Go to step 7B7.  
**NO** : Repair front wiring harness.

**7B7 CHECK RELAY BOX.**

- 1) Turn ignition switch to OFF.
- 2) Connect connector (F50) to relay box.
- 3) Remove valve relay from relay box.
- 4) Disconnect connector (ABS1) from hydraulic control unit.
- 5) Turn ignition switch to ON.

**CHECK** : **Does the ABS warning light remain off?**  
**YES** : Go to step 7B8.  
**NO** : Repair relay box and check fuse.



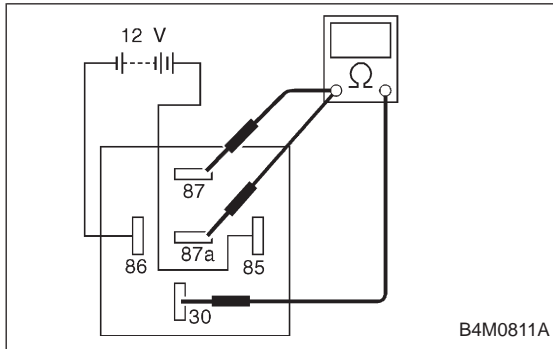
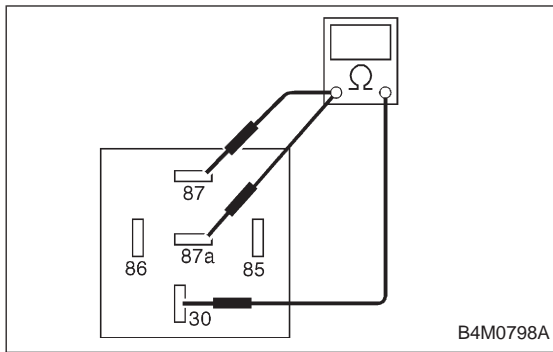

<b>7B8</b>	<b>CHECK VALVE RELAY.</b>
------------	---------------------------

1) Measure resistance between valve relay terminal and terminal.

**CHECK** : **Terminals**  
**No. 30 — No. 87:**  
**Is resistance more than 1 MΩ?**  
**No. 30 — No. 87a:**  
**Is resistance less than 0.5 Ω?**

**YES** : Go to next step.

**NO** : Replace valve relay.

2) Connect battery to valve relay terminal No. 85 and No. 86.

3) Measure resistance between valve relay terminals.

**CHECK** : **Terminals**  
**No. 30 — No. 87:**  
**Is resistance less than 0.5 Ω?**  
**No. 30 — No. 87a:**  
**Is resistance more than 1 MΩ?**

**YES** : Go to step 7B9.

**NO** : Replace valve relay.

<b>7B9</b>	<b>CHECK HYDRAULIC CONTROL UNIT.</b>
------------	--------------------------------------

1) Turn ignition switch to OFF.

2) Connect connector (ABS1) to hydraulic control unit.

3) Turn ignition switch to ON.

**CHECK** : **Is the ABS warning light off?**

**YES** : Go to step 7B10.

**NO** : Replace hydraulic control unit and check fuse No. 19.

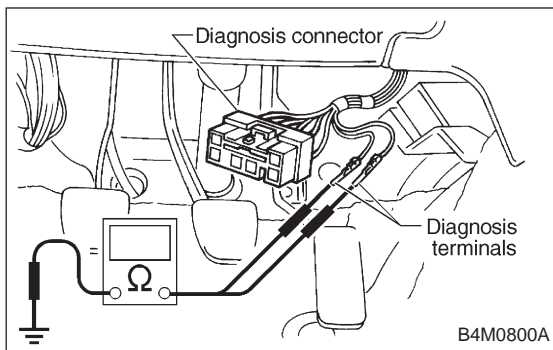

**7B10 CHECK DIAGNOSIS TERMINAL.**

Measure resistance between diagnosis terminals (B81) and chassis ground.

**CHECK** : *Terminals*  
**Diagnosis terminal (A) — Chassis ground:**  
**Diagnosis terminal (B) — Chassis ground:**  
**Is the resistance less than 1 Ω?**

**YES** : Go to step 7B11.  
**NO** : Repair diagnosis terminal harness.

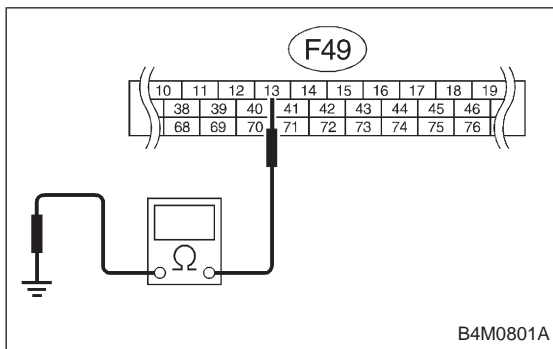

**7B11 CHECK DIAGNOSIS LINE.**

- 1) Turn ignition switch to OFF.
- 2) Connect diagnosis terminal to diagnosis connector (B82) No. 6.
- 3) Disconnect connector from ABSCM.
- 4) Measure resistance between ABSCM connector and chassis ground.

**CHECK** : *Connector & terminal*  
**(F49) No. 13 — Chassis ground:**  
**Is the resistance less than 1 Ω?**

**YES** : Go to step 7B12.  
**NO** : Repair harness connector between ABSCM and diagnosis connector.

**7B12 CHECK POOR CONTACT IN ABSCM CONNECTOR.**

**CHECK** : *Is there poor contact in ABSCM connector?*

**YES** : Repair connector.  
**NO** : Replace ABSCM.

**C: TROUBLE CODE DOES NOT APPEAR.****DIAGNOSIS:**

- Diagnosis circuit is open.

**TROUBLE SYMPTOM:**

- The ABS warning light turns on or off normally but the start code cannot be read out in the diagnostic mode.

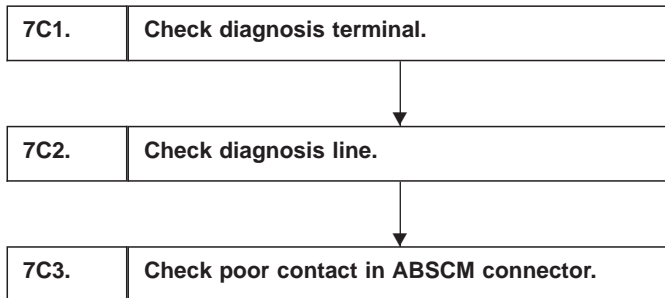

**WIRING DIAGRAM:**

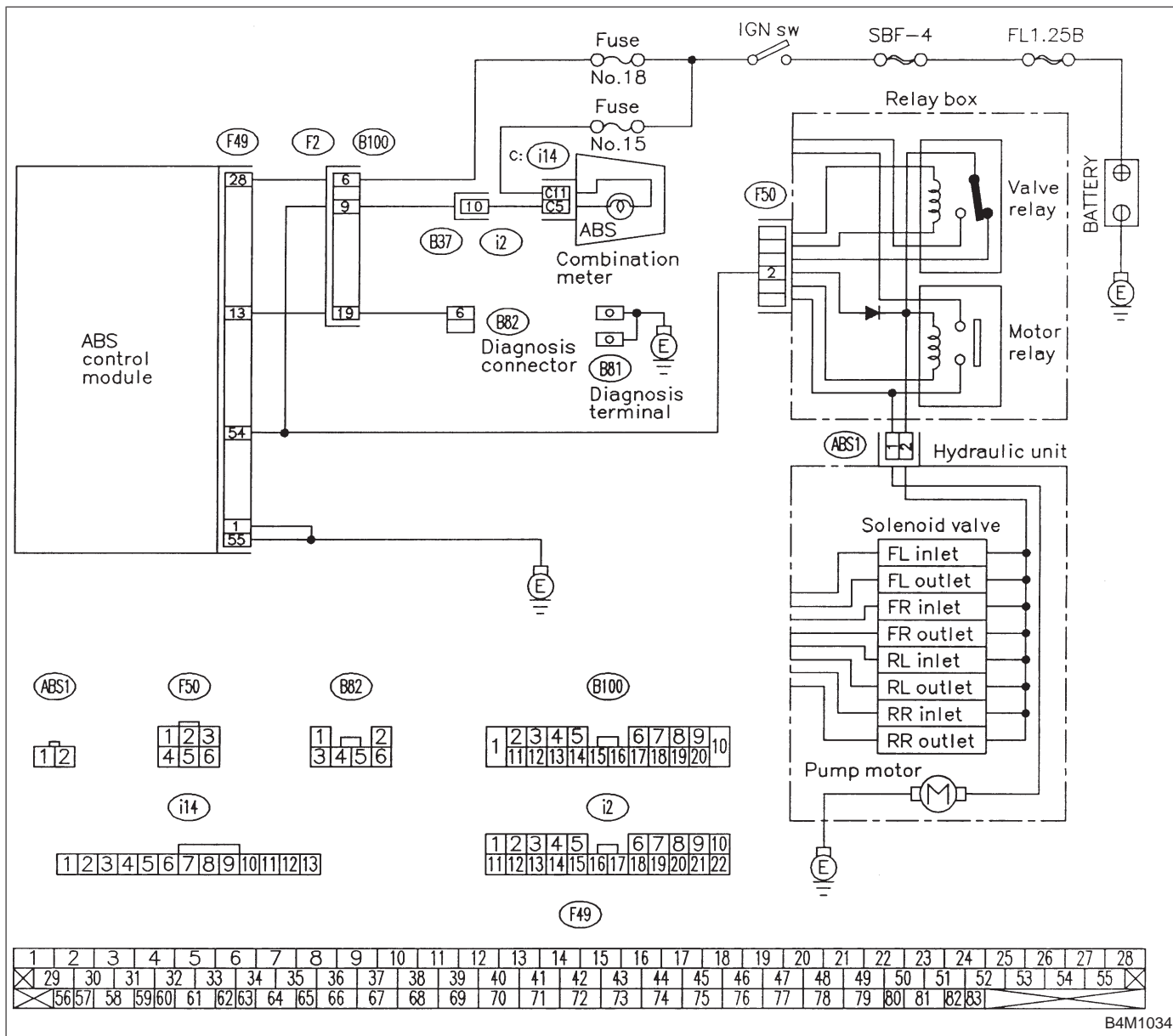

B4M1034

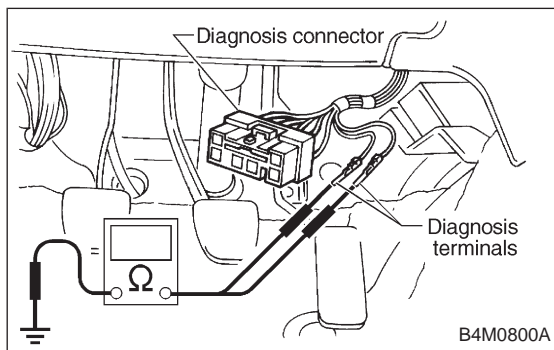

B4M0800A

<b>7C1</b>	<b>CHECK DIAGNOSIS TERMINAL.</b>
Measure resistance between diagnosis terminals (B81) and chassis ground.	
<b>CHECK</b>	: <b>Terminals</b> <b>Diagnosis terminal (A) — Chassis ground:</b> <b>Diagnosis terminal (B) — Chassis ground:</b> <b>Is the resistance less than 0.5 Ω?</b>
<b>YES</b>	: Go to step 7C2.
<b>NO</b>	: Repair diagnosis terminal harness.

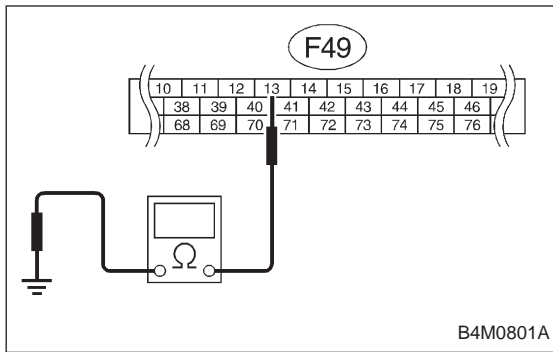

<b>7C2</b>	<b>CHECK DIAGNOSIS LINE.</b>
------------	------------------------------

- 1) Turn ignition switch to OFF.
- 2) Connect diagnosis terminal to diagnosis connector (B82) No. 6.
- 3) Disconnect connector from ABSCM.
- 4) Measure resistance between ABSCM connector and chassis ground.

**CHECK** : **Connector & terminal (F49) No. 13 — Chassis ground: Is the resistance less than 0.5 Ω?**

**YES** : Go to step 7C3.

**NO** : Repair harness connector between ABSCM and diagnosis connector.

<b>7C3</b>	<b>CHECK POOR CONTACT IN ABSCM CONNECTOR.</b>
------------	-----------------------------------------------

**CHECK** : **Is there poor contact in ABSCM connector?**

**YES** : Repair connector.

**NO** : Replace ABSCM.